

THE INFORMATION CONTAINED HEREIN IS CONFIDENTIAL AND PROPRIETARY TO ALAMARIN-JET AND IS NOT TO BE REPRODUCED, COPIED, DISCLOSED OR DISTRIBUTED WITHOUT THE WRITTEN PERMISSION OF ALAMARIN-JET OR ITS DULY AUTHORIZED REPRESENTATIVE. ALL RIGHTS RESERVED.

1. Reverse deflector hydraulic cylinder connection. Standard 33C cable fitting.
2. Input flange DIN-150. Adapter plate must be used for different intermediate shaft configuration.
3. Cooling water intake in both sides. G1" (1" BSP) thread.
4. Steering lever to be connected to steering system. See installation manual for more information.

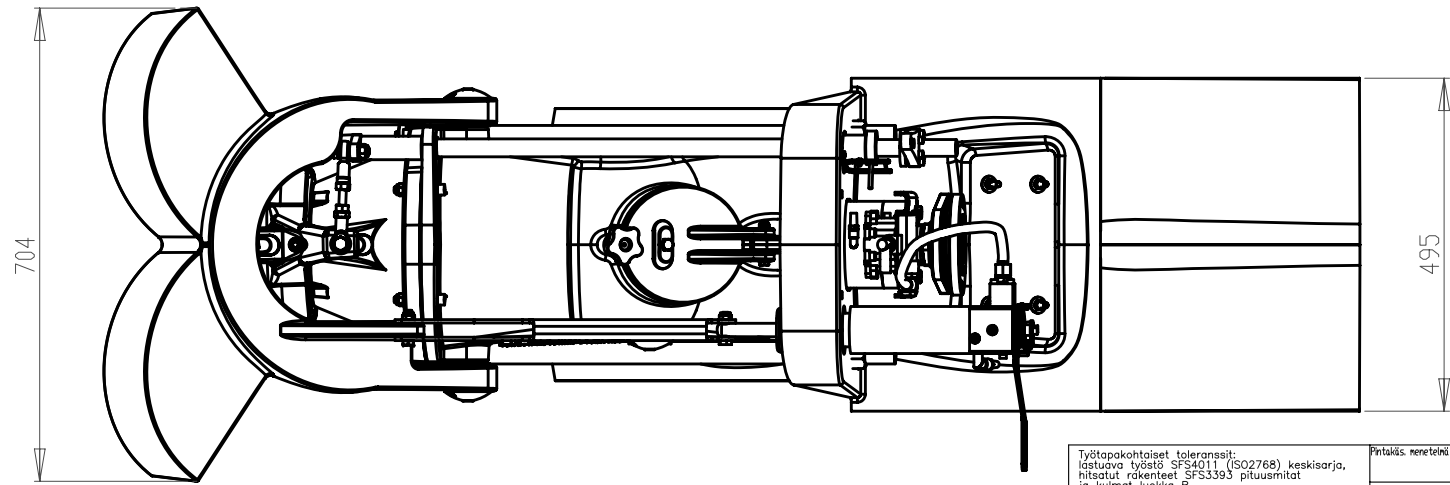
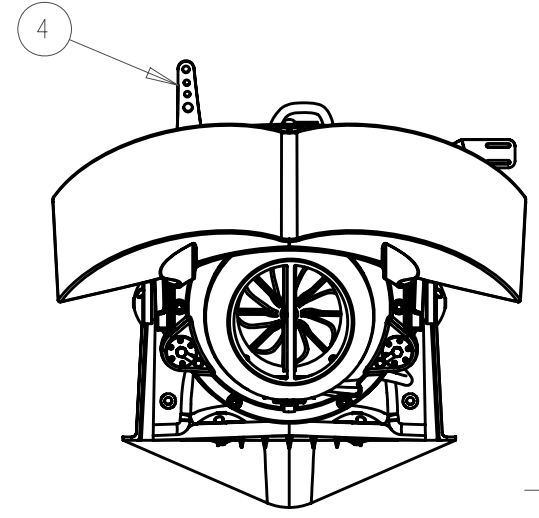
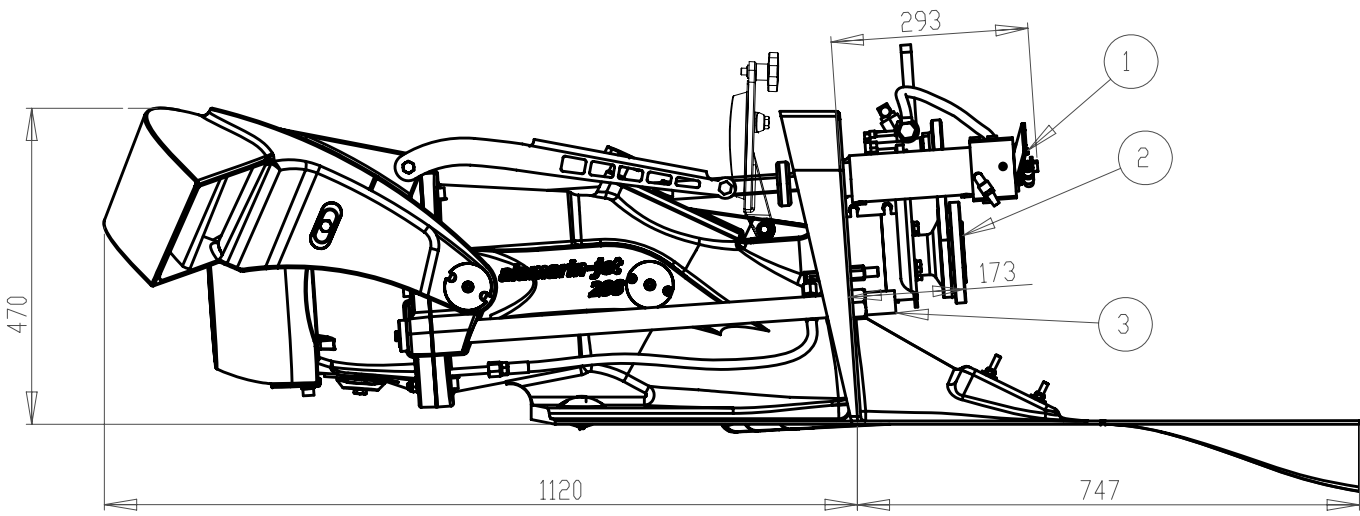

Työtapaohjeiset toleranssit: laatuva työväline SFS4011 (ISO2768) keskisarja, hitsatut rakenteet SFS3393 piliusmitat ja kuumat luokka B, muoto ja sijaintitoleranssit DIN8570BL3 luokka E, valukappaleet SFS-ISO8062		Pintakäs. menetelmä - Surf. treatn. Sävy - Colour	Pinta-ala - Surf. area (m ²) PAINO - Weight (kg) 120	Suun. Design. Draw. Hyväk. Mepp.	Ver.- Rev. A A
alamarinjet		Tuotekoodi Jet-288	Koko Size A3	Mitta-kaava Scale 1:8	Sivut Sheet 1/1

A	Muutoksen ja korjauksen selitys Amendment and correction explanation	Pvm Date	Muutettu Modified	Hyväksytty Approved
---	---	-------------	----------------------	------------------------